

Parameters	P30L	P30EXL	P50L	P220L
Type of actuator	Linear high speed	Linear high speed ATEX	Linear	Linear
Force [kN]	3-12	3-12	4-16	6-40
Standard screw pitch [mm]	10	10	10	25
Speed [mm/min]	400	400	25 ¹⁾	60 ¹⁾
Working range [mm]	330 (1600 ²⁾)	330 (1600 ²⁾)	330 (1600 ²⁾)	330 (1600 ²⁾)
Precision [mm]	± 0.10	± 0.10	± 0.15	± 0.20
Sealing	IP67	IP67	IP67	IP67
Surrounding temp [°C]	-20 – +60	-20 – +60	-20 – +60	-20 – +60
Max standard stroke [mm]	40/100	40/100	40/100	100
Installation in all directions	Yes	Yes	Yes	Yes
ATEX-certified	No	Yes	No	No
Weight (kg)	7	7	9	14

Electrical data	P30L	P30EXL	P50L	P220L
Type of motor	Brushless	Brushless	Step	Step
Voltage [VDC]	24 ± 15%	24 ± 15%	24 ± 15%	24 ± 15%
Max. power [W]	200	200	70	120
Average power [W]	100	100	35	60
Max. current [A]	8	8	3	5
Average current [A]	2	2	1	2
Analogue control [mA]	4-20	4-20	4-20	4-20
Return (position) signal [mA]	4-20	4-20	4-20	4-20

Material data	
Aluminium servo housing	SS 4212-06, blue anodizing
Aluminium components	SS 4212-06, black anodizing
Steel components	SS 2346, SS 2333

1) Speed depending on chosen force.
2) UPS needed.

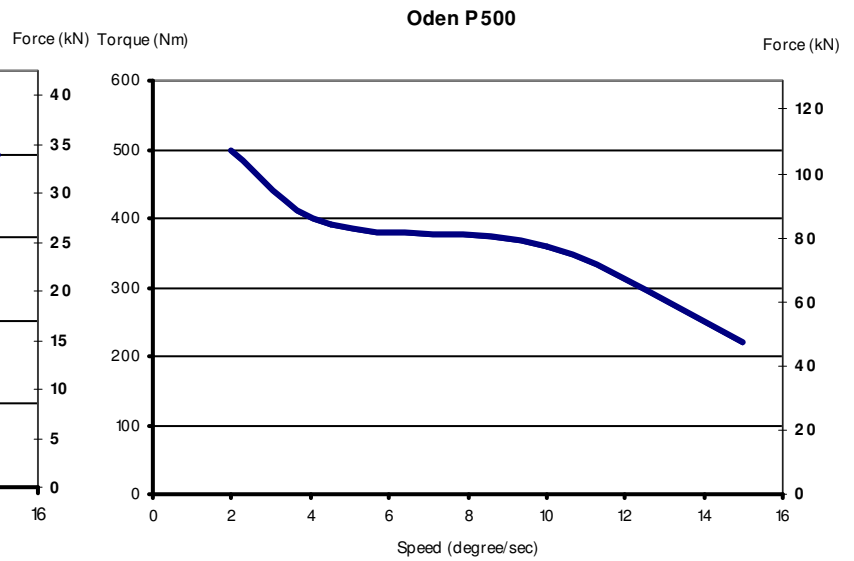
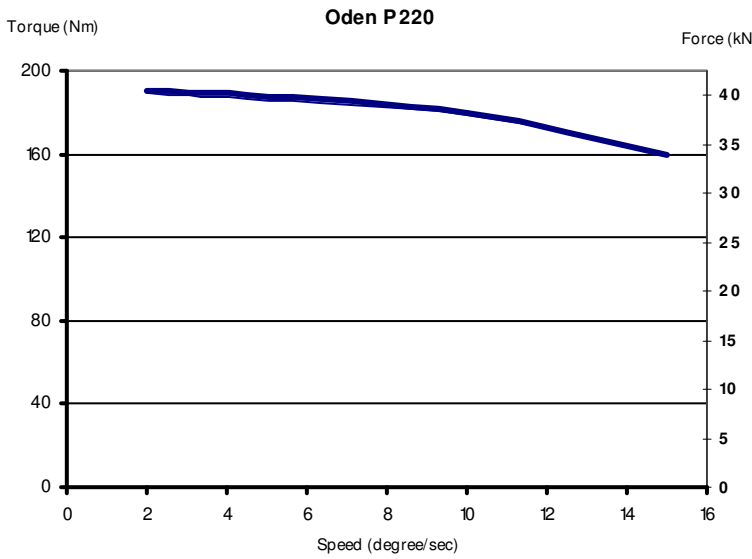
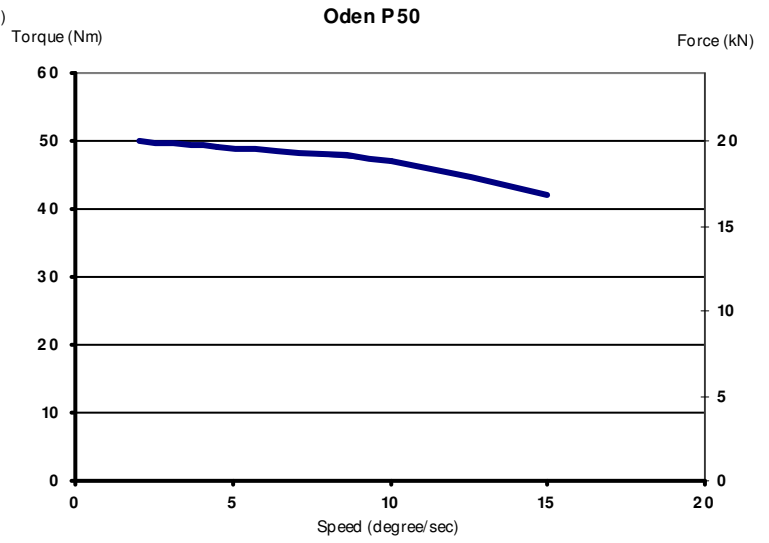
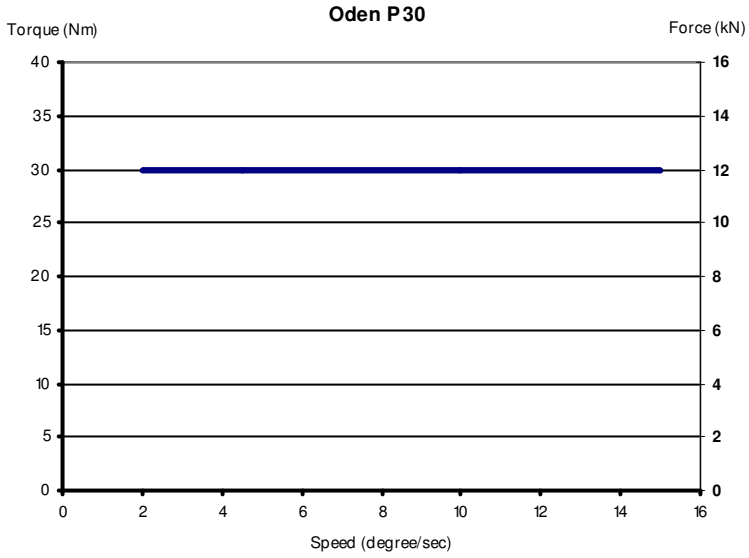

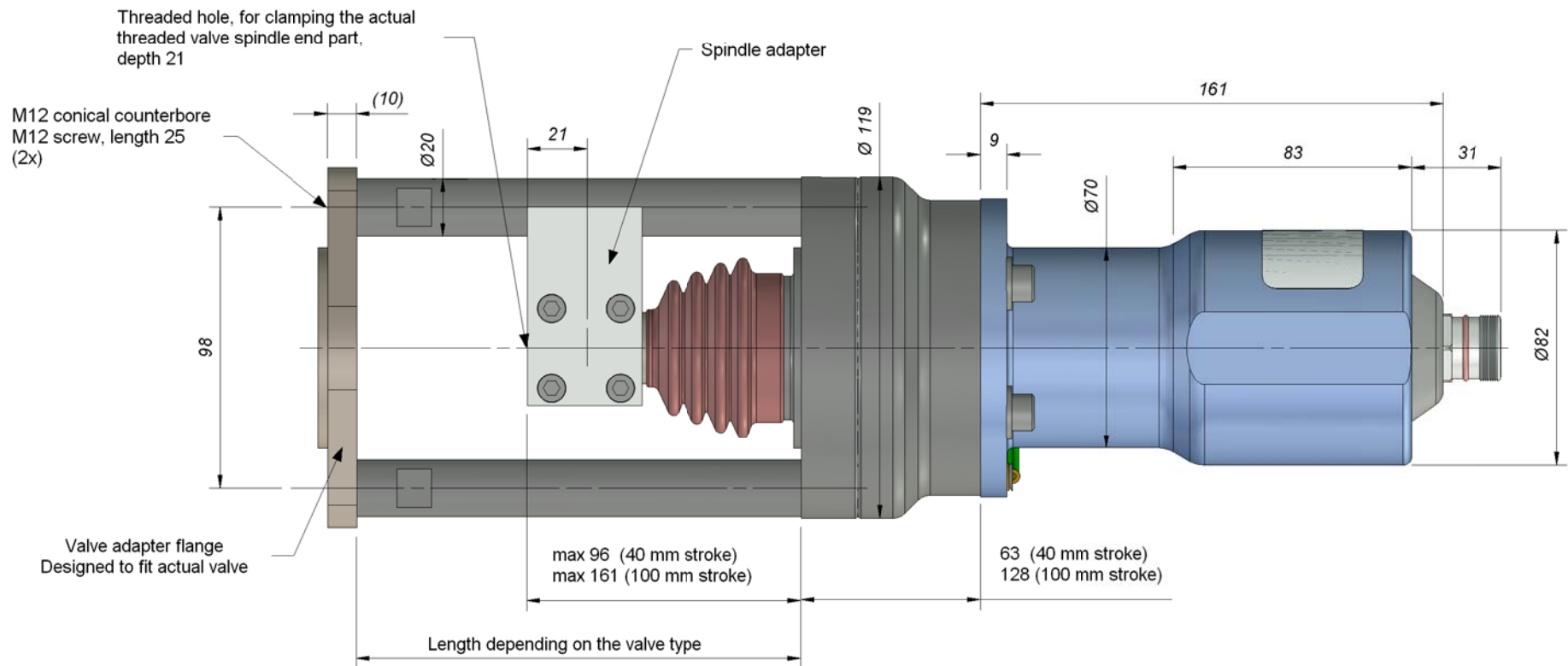

Standard strokes 40 mm and 100 mm

This document must not be copied, either completely or in part, without our permission. Any infringement will lead to legal proceedings.
Oden Control AB (publ.) org.nr. 556 529-7057

Oden Control AB
Nilstorpsvägen 53 181 47 Lidingö, Sweden
Phone +46-8-767 76 57 Fax +46-8-767 47 18
E-mail oden@odencontrol.se www.odencnrol.se

**P30L1 linear
actuator**
(ID1-drawing)

Dat./rev.nr	2006.07.10
Sheet	1
Doc.Nr	P30.111

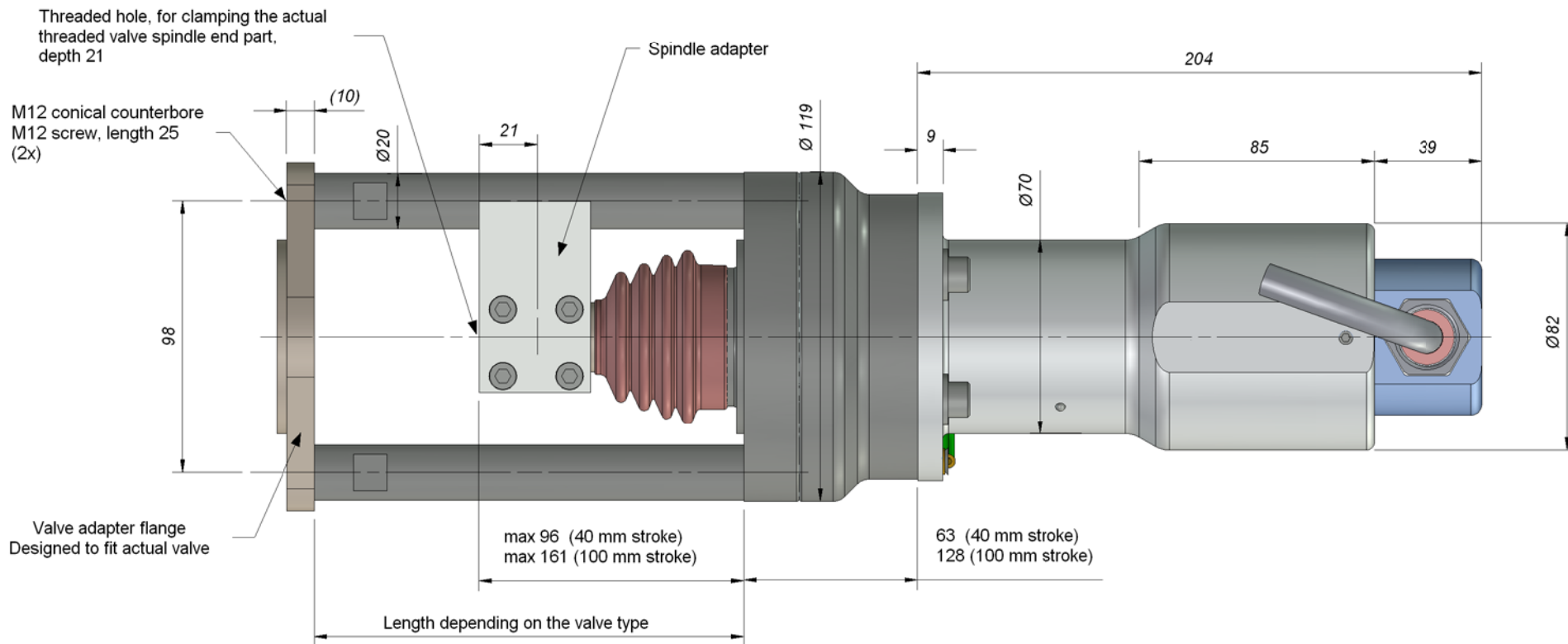

Standard strokes 40 mm and 100 mm

This document must not be copied, either completely or in part, without our permission. Any infringement will lead to legal proceedings.
Oden Control AB (publ.) org.nr. 556 529-7057

Oden Control AB
Nilstorpsvägen 53 181 47 Lidingö, Sweden
Phone +46-8-767 76 57 Fax +46-8-767 47 18
E-mail oden@odencontrol.se www.odencnrol.se

**P30EXL1 linear
actuator**
(ID1-drawing)

Dat./rev.nr	2006.07.10
Sheet	1
Doc.Nr	P30.112

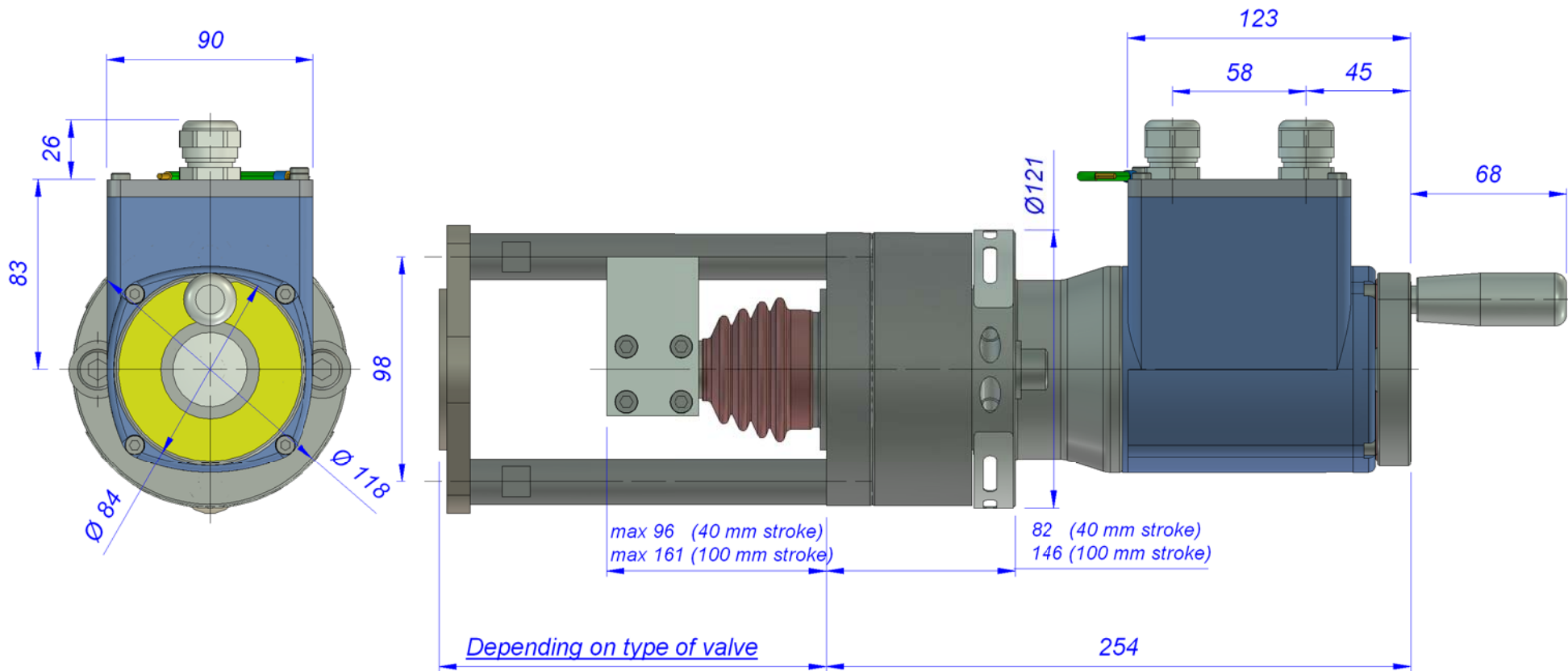

Dat./rev.nr	2006.06.15
Sheet	1
Doc.Nr	P50.021

Oden Control AB
 Nilstorpsvägen 53 181 47 Lidingö, Sweden
 Phone +46-8-767 76 57 Fax +46-8-767 47 18
 E-mail oden@odencontrol.se www.odencontrol.se

Title
P50L
linear actuator
(ID1-drawing)

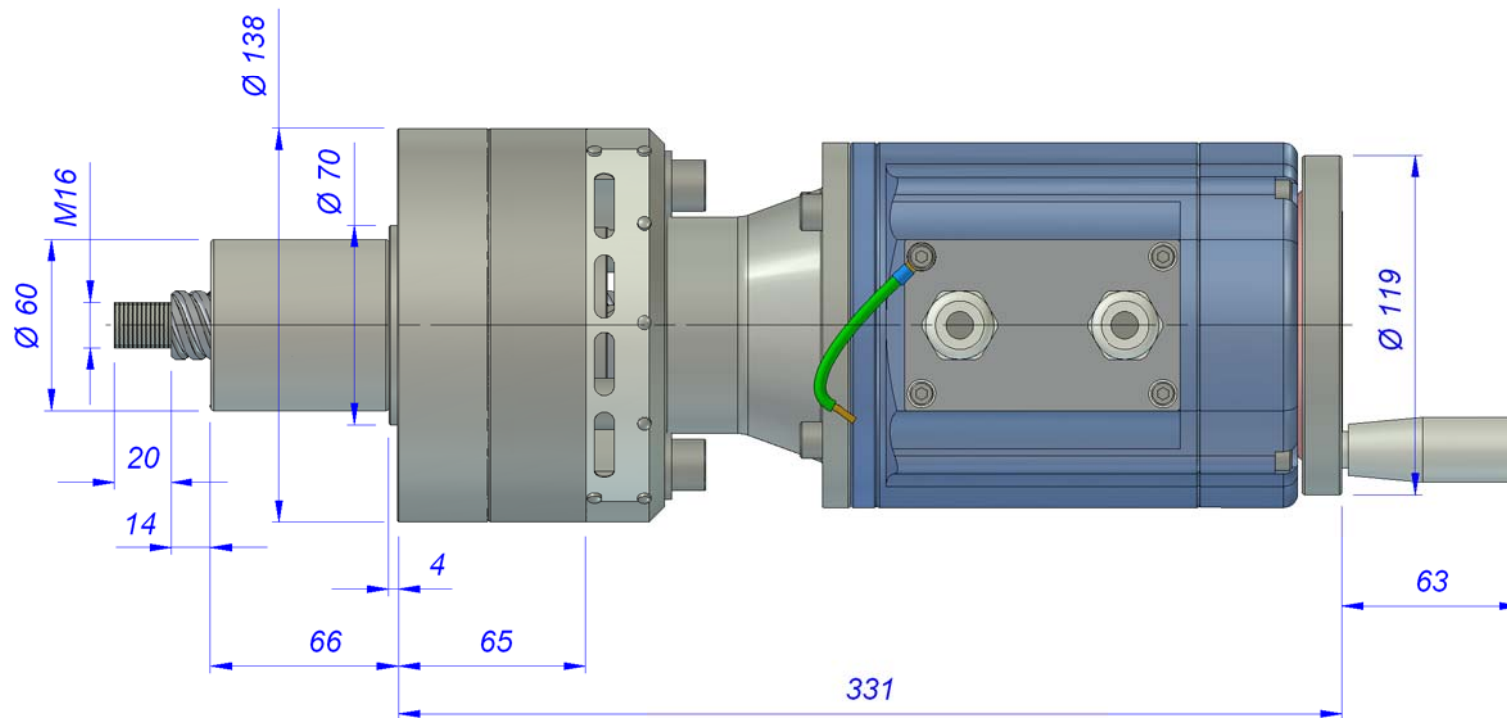

Oden Control AB

Nilstorpsvägen 53 181 47 Lidingö, Sweden
 Phone +46-8-767 76 57 Fax +46-8-767 47 18
 E-mail oden@odencontrol.se www.odencontrol.se

Title

P220L
linear actuator
(ID1-drawing)

Dat./rev.nr

2006.06.13

Sheet

1

Doc.Nr

P220.041